

MSR211P

Description

The MSR211P forms one of the base units for the modular Minotaur MSR200 family of monitoring safety relays. It can be combined with other modules of the MSR200 Series to configure a safety control system with numbers of inputs and outputs matching users' specific application requirements, as well as diagnostic and networking capabilities. Up to ten input modules and two output modules can be connected to one base unit by simply removing the terminator, included with each base unit, and connecting the ribbon cables of the neighboring module. The terminators must be inserted into the final input and output modules.

The MSR211P has two inputs. Each input can be wired in one of three ways: one normally closed, two normally closed, or two OSSD connections from a light curtain. The MSR211P does not perform cross fault monitoring, and would not detect a short across the inputs of a two normally closed input. When connected to light curtains, the light curtain must perform the cross fault detection.

The MSR211P has the capability to perform external device monitoring (EDM). The EDM capability works in conjunction with the reset option. The user selects EDM and the reset function by jumpers across terminals Y40, Y41 and Y42.

The MSR211P has two semiconductor outputs designed to send status information to a PLC. Terminal Y33 indicates the inputs are closed (the ready LED is on). Terminal Y32 indicates the outputs are active.

The outputs include two normally open safety rated outputs and one normally closed auxiliary output.

Features

- Category 4 per EN 954-1
- Stop category 0
- Two input circuits: light curtain, safety gate, or E-stop inputs
- Two safety outputs, three auxiliary outputs
- Ten diagnostic LEDs
- Monitored or automatic reset
- Removable terminals

LED Indicators

Green	Input 1 Closed
Red	Input 1 Open
Green	Input 2 Closed
Red	Input 2 Open
Green	CH1 Output Active
Green	CH2 Output Active
Green	Power
Green	Run (Outputs Active)
Red	Stop (Outputs Off) + Diagnostics
Amber	Ready (Inputs Closed)

Specifications

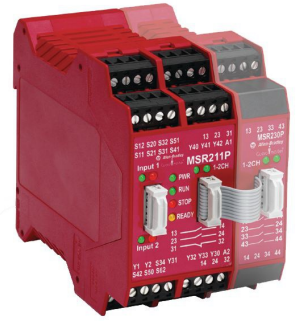

Safety Ratings		
Standards	EN 954-1, ISO 13849-1, IEC/EN 60204-1, IEC 60947-4-1, IEC 60947-5-1, ANSI 11.19, AS 4024.1	
Safety Classification	Cat. 4 per EN 954-1 (ISO 13849-1), SIL CL3 per EN IEC 62061, PLe per ISO 13849-1	
Functional Safety Data * Note: For up-to-date information, visit http://www.ab.com/safety/	PFH _D : < 3.49 x 10 ⁻⁹ MTTF _d : > 188 years Suitable for performance levels PLe (according to ISO 13849-1:2006) and for use in SIL3 systems (according to IEC 62061) depending on the architecture and application characteristics	
Certifications	CE Marked for all applicable directives, cULus, c-Tick, and TÜV	
Power Supply		
Input Power Entry	24V DC 0.8...1.1 x rated voltage	
Power Consumption	8 W	
Inputs		
Safety Inputs	Two Inputs 1 N.C. or 2 N.C. or LC	
Input Simultaneity	Infinite	
Input Resistance, Max.	Inputs: 900 Ω Reset: 3200 Ω	
Reset	Auto./Manual or Monitored Manual	
Power On Delay/ Recovery Time	3 seconds/40...145 ms, depending on expansion modules used	
Response Time	MSR211: 25 ms MSR211+ MSR221.: 30 ms+2.4 ms per MSR221	
Outputs		
Safety Contacts	2 N.O.	
Auxiliary Contacts	1 N.C., 2 PNP	
Thermal Current I _{th}	1 x 6 A or 2 x 4 A (nonswitching)	
Rated Impulse withstand Voltage I _{th}	2500V	
Switching Current @ Voltage, Min.	10 mA @ 10V DC	
Fuses, Output	External 6 A slow blow or 10 A quick blow	
Solid State Output Rating	20 mA @ 30V DC short-circuit protection	
Electrical Life (Operations)	220V AC/4 A/880VA cosφ = 0.35...0.1 M 220V AC/1.7 A375VA cosφ = 0.6...0.5 M 30V DC/2 A/60 W = 1 M 10V DC/0.01 A/0.1 W = 2 M	
Mechanical Life	2,000,000 cycles	
Utilization Category		
Resistive: AC-1	6 A @ 250V AC	
Resistive: DC-1	6 A @ 24V DC	
Inductive: AC-15	3 A @ 250V AC B300	3 A @ 125V AC
Inductive: DC-13	2.5 A @ 24V DC	
UL	1 x B300, R300 or 2 x C300 1 x 6 A or 2 x 4 A Resistive	
Environmental and Physical Characteristics		
Enclosure Type Rating/ Terminal Protection	IP40 (NEMA 1)/ IP20	
Operating Temperature [C (F)]	-5...+55 ° (23...131 °)	
Vibration	10...55 Hz, 0.35 mm	
Shock	10 g, 16 ms, 100 shocks	
Mounting	35 mm DIN Rail	
Weight [g (lb)]	280 (0.62)	
Conductor Size, Max.	0.2...4 mm ² (24...12 AWG)	

* Usable for ISO 13849-1:2006 and IEC 62061. Data is based on the following assumptions:

- Mission time/Proof test interval of 20 years
- Functional test at least once within six-month period

Product Selection

Inputs	Safety Outputs	Auxiliary Outputs	Solid State Outputs	Terminals	Reset Type	Power Supply	Cat. No.
Two independent inputs; 2 x 1 N.C., 2 N.C., or Light Curtain	2 N.O.	1 N.C.	2 PNP	Removable	Auto./Manual or Monitored Manual	24V DC from the base unit	440R-H23177

Accessories

Description	Cat. No.
MSR200, Two Terminators	440R-A17138
Bag of 4, 4-Pin Screw Terminal Blocks	440R-A23209
Bag of 4, 4-Pin Spring Clamp Terminal Blocks	440R-A23228

Diagnostics—Red Stop LED Blinks

Blink Rate	Description
2	Change in Y40/Y41/Y42 circuit during operation.
3	Fault in external feedback circuit Y1-Y2. Clear fault and cycle power to reset the module.
Continuous	Internal fault in base or expansion module.

Approximate Dimensions

Dimensions are shown in mm (in.). Dimensions are not intended to be used for installation purposes.

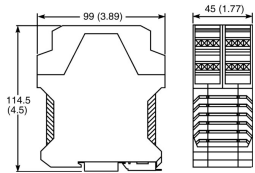

Block Diagram

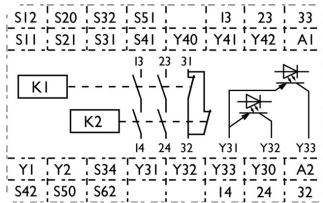

Typical Wiring Diagrams

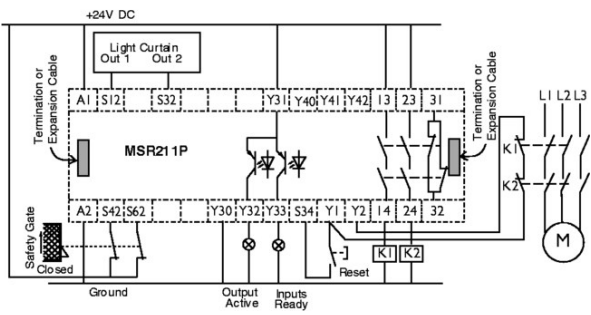

Light Curtain and Dual Channel Safety Gate,
Monitored Manual Reset, Monitored Output

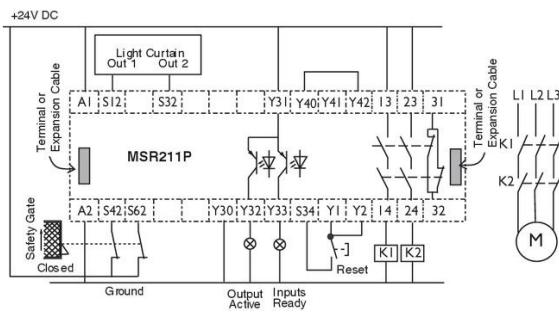

Light Curtain and Dual Channel Safety Gate,
Monitored Manual Reset, No Monitored Output

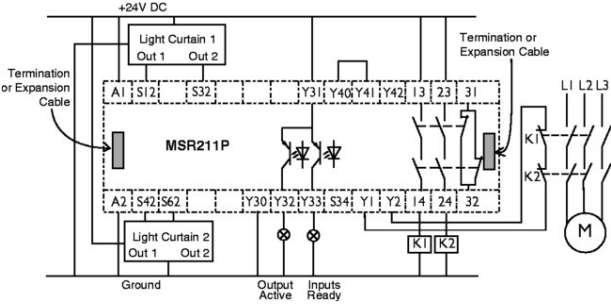

Two Light Curtains,
Automatic Reset, Monitored Output